



VR STRIPS

Sealing strips for insulating vertically sash windows against cold, drafts, and noise. Smart and valuable insulation with VR Strips.

Content

- 2 frame strips 
- 2 window strips 
- 2 O-profiles, 10 mm and 6 mm 
- Torx 6 mounting screws
(per set for one window)
- 1 Torx bit size 6
- VR Finish

Tools

- 1 router
- 1 cutting knife or small saw
- optional: 3mm groove saw
- clean cloth
(not included)

Application

VR Strips are suitable for sash top and bottom windows. A combination with two sash parts is also possible.

VR Strips are designed for a window thickness (d) starting from 36mm, but can also be used if a 10x12mm groove can be made on the sides of the sash window, provided that nothing obstructs the groove. This makes it possible to use them with thinner wood in many cases.

The height of the sash part (h) and the sash height cannot be greater than the length of the side profiles, as specified on the packaging tube of the VR Strips. Other lengths are available upon request.

The sash window cannot be wider (b) than the length of the O-profiles. These are standard 1500mm. Other lengths are available upon request.

This technique is suitable for both sash windows with counterweights and systems with balance springs. The system does not affect the balancing system and does not limit the weight of the sash window.

VR Strips are designed to absorb any play in the (old) window. The window can therefore be slightly bent, crooked, or tilted. Some wood may have worn away. The difference in all directions can be about 5mm. In many cases, larger deviations can also be accommodated by installing the VR Strips cleverly. However, it may result in a slight decrease in insulation performance or make sashing a bit more difficult. See later in this manual for more details.

This is a general guide. Each restoration window is unique, so also use your own judgment and experience when applying the VR Strips.

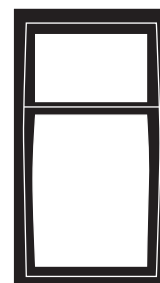
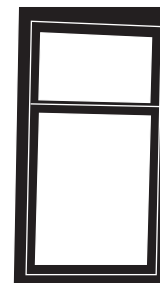
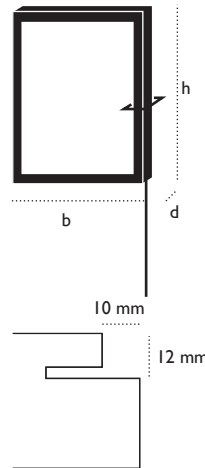
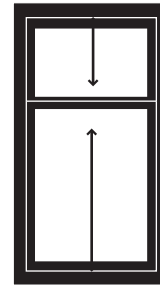

More information can be found at www.vanruysdael.com

HappyLift BV

Kadijk 16 | 8531 XD Lemmer | The Netherlands
www.happylift.nl | sales@happylift.nl

Content

I	manual for sash bottom window	3
II	manual for sash top window	7
III	details & alternatives	11
IV	special situations	19
V	extras & extensions	21
VI	use & maintenance	22
VII	possible issues	23

I Manual for sash bottom window

Sash the window all the way open, carefully disconnect the balancing system, and remove the sash window from the frame.

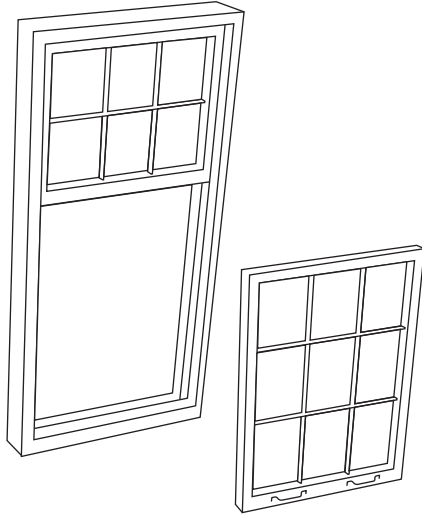

- . Ensure that the window is always stable and secure before disconnecting the balancing system.
- . Remove any trim or cover strips.
- . For a system with counterweights, carefully disconnect the weights and lift the window out of the frame.
- . Note that in a frame with sash top and bottom windows, the weight may be connected to both sash parts.
- . For a spring system, remove any end stops, sash the window upward, support it securely, and carefully disconnect the springs.

2 Route rebates in the sash window on the left/right and top/bottom, creating a groove across the entire width.

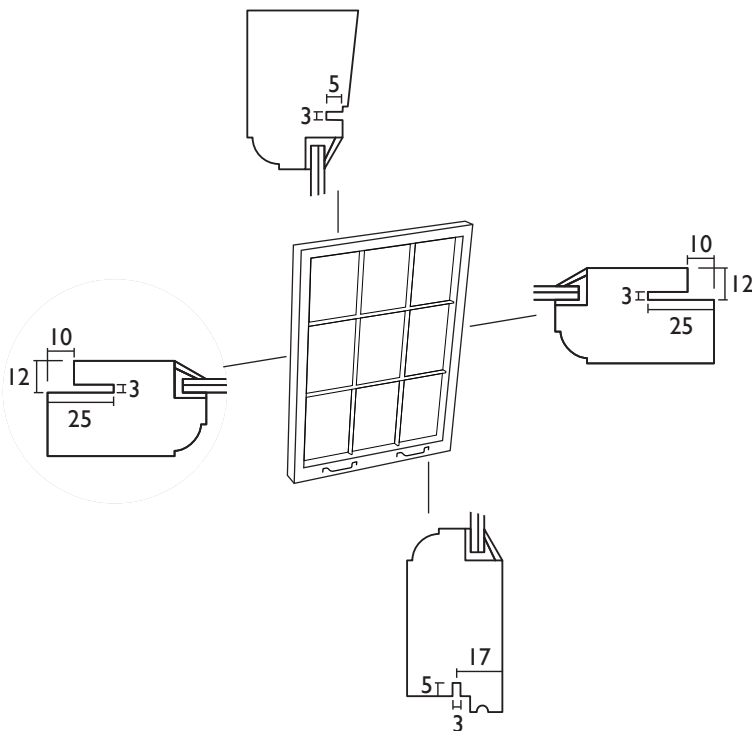

- . Route or saw the side rebates (10x12mm and a 3mm groove) using a router and/or groove saw along the entire side of the sash window on both sides.
- . When routing, follow the edge of the sash window.
- . If the window is significantly bent or worn, adjust these measurements according to section D in this guide.
- . Route a 3mm wide groove, about 5mm deep, along the entire width at the bottom, by the sill. preferably, maintain the measurement (17mm from the outside) for optimal sealing with the sides.
- . Provide the top, the movable sill, with the same groove across the entire width. do this at the point where the angled or flat protruding edges of both window parts meet, ensuring there is room for a 6mm O-ring.
- . If necessary, adjust the movable sill with a small strip of wood to accommodate the groove in both parts. see also C-04.

I manual for sash bottom window

- 3** Cut the window strips on the left and right to the correct height, trim the O-profiles at the top (small) and bottom (large) to the correct width and press them into the rebates of the sash window.

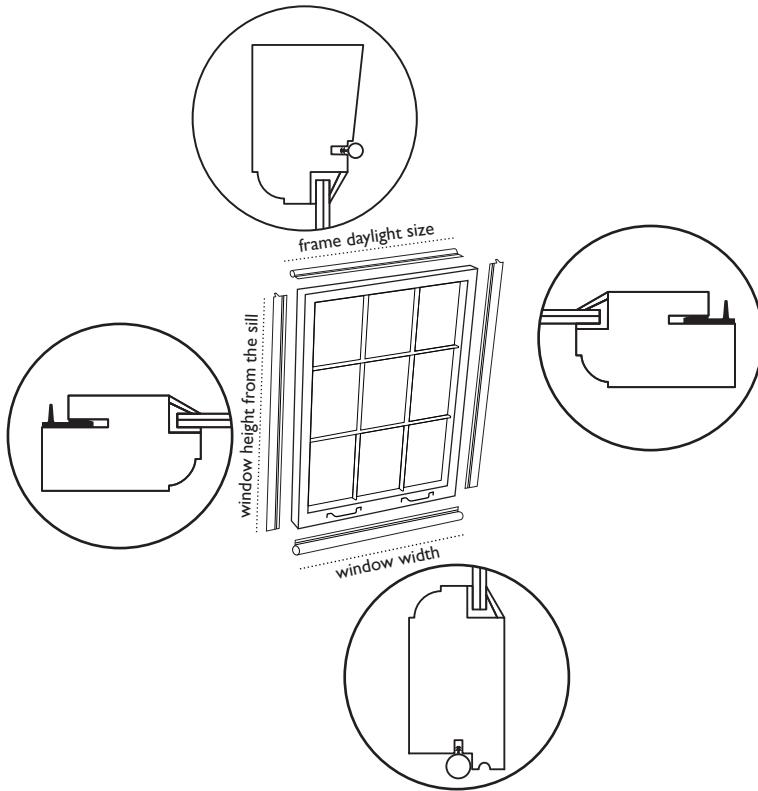

- Trim the window profiles to match the height of the sash window.
- Ensure that, in the closed position, the profile aligns with the top of the sash window.
- Take into account a slanted sill at the bottom or any gap between the sash window and the sill in the closed position, particularly at the side grooves (see drawing).
- A slight deviation in this measurement is not a problem, but a profile that is too long may be visible, while a profile that is too short might allow more air and drafts to pass through.
- Press these profiles with the sawtooth ribs into the sash window on the left and right sides. Tap the profile so that the outer edge aligns with the side of the wood for proper positioning (see drawing).
- Adjust this for a significantly warped or worn window according to the alternative detailing in section D
- Ensure that, in the closed position, the profile aligns exactly with the bottom sill.
- If the routed groove is too large, the profile can be secured with a small amount of glue or held in place with a few nails.
- Cut a small O-profile (6mm Ø) to size so that it fits precisely within the daylight opening of the frame (see drawing), and press it into the groove made at the movable sill.
- Cut a large O-profile (10mm Ø) to size so that it fits precisely within the left-right guidance, the rebate size (see drawing), and press it into the underside.
- Do not stretch these profiles when cutting to size or during installation.

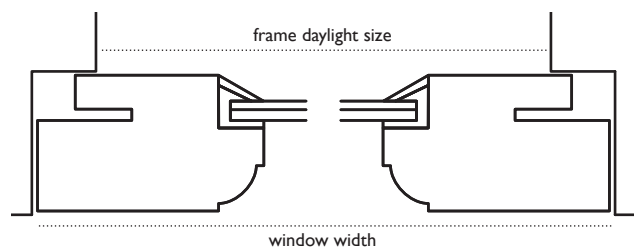

I manual for sash bottom window

- 4** Cut the frame strips to this height measurement and screw them into the corners of the frame on the left and right, at the bottom up to the sill, using the appropriate Torx 6 bit.

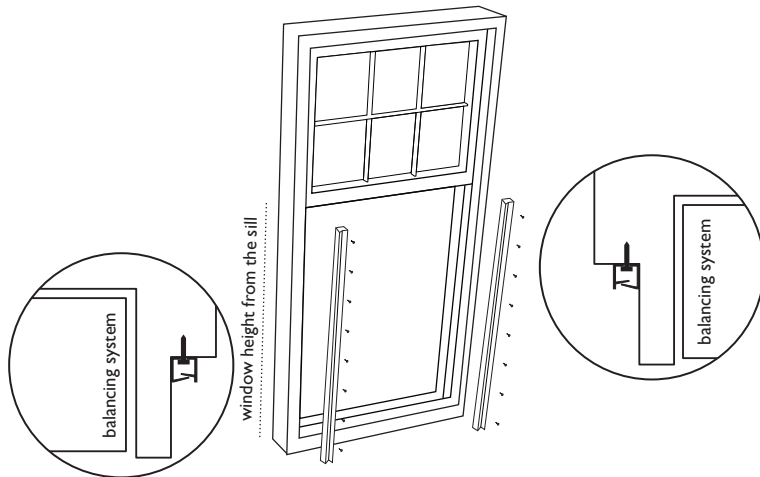

- . Trim the frame profiles (black-gray U-shape) to the same size as the window profiles (black L-shape). The profiles have no specific left or right side for use.
- . Pay attention to the shape of the sill, but leave a few millimeters of clearance on the outer side for drainage.
- . If the window has a sash height greater than the height of the sash window, always keep the frame profile slightly longer than the final sash height to ensure the profiles remain partially nested. See also D-02.
- . Screw the profiles into the window guide of the frame using the supplied screws and a suitable Torx 6 bit, securing them at the bottom against the sill (drainage).
- . Use all the holes in the profiles and tighten the screws just enough to touch the profile, avoiding over-tightening, which could damage the profile.
- . The easiest method is to first turn the screws one rotation into the shortened profiles on a table to hold them in place, then position the profiles in the frame and fully tighten them.

- 5** Dampen a clean cloth with VR Finish or silicone spray and wipe the frame profiles with it. Be careful not to touch the woodwork, as it may affect the adhesion of the paint.

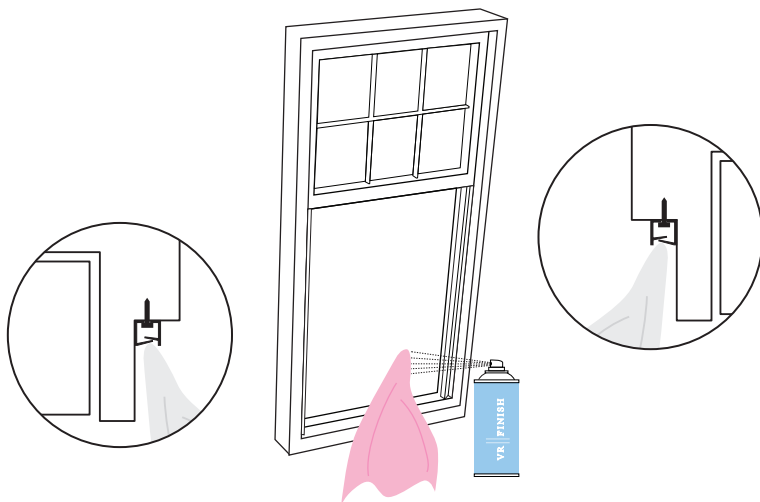

- . Check that the frame profiles are free of dust and dirt, and clean them if necessary with a cloth, optionally using a mild cleaning agent, before applying VR Finish.
- . Evenly coat both lips of the frame profiles with a thin layer of VR Finish.
- . Avoid contact between the frame profiles and dust or dirt after this step to ensure optimal performance.

I manual for sash bottom window

- 6** Carefully place the sash window back into the frame, ensuring that the window profiles fit into the frame profiles, and reconnect the balancing system.

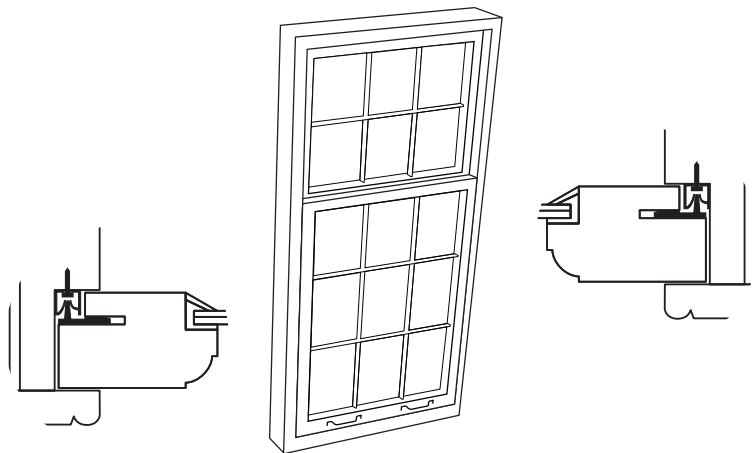

Reinstall the window into the frame, ensuring that the profiles interlock properly (see drawing). Approach the frame as straight as possible from the inside to ensure the profiles are immediately well-positioned relative to each other. Stabilize the window securely before letting go. Reconnect the balancing system.

If the sash window has been updated with insulated glass, be aware that the balancing system may need to be adjusted to accommodate the new weight for smooth operation. Replace the springs or weights as needed, or safely add extra weight to the existing counterweights.

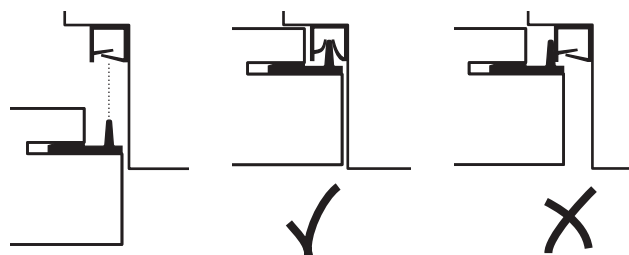

Manual for sash top window

Sash the window all the way open, carefully disconnect the balancing system, and remove the sash window from the frame.

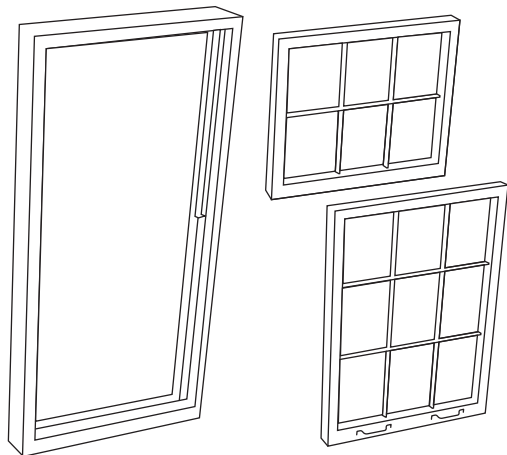

- . Ensure that the window is always stable and secure before disconnecting the balancing system.
- . Remove any trim or cover strips.
- . For a system with counterweights, carefully detach the weights and lift the window out of the frame.
- . For a spring system, remove any end stops, slide the window upward, support it securely, and carefully disconnect the springs.

2 Route rebates in the sash window on the left/right and top/bottom, creating a groove across the entire width.

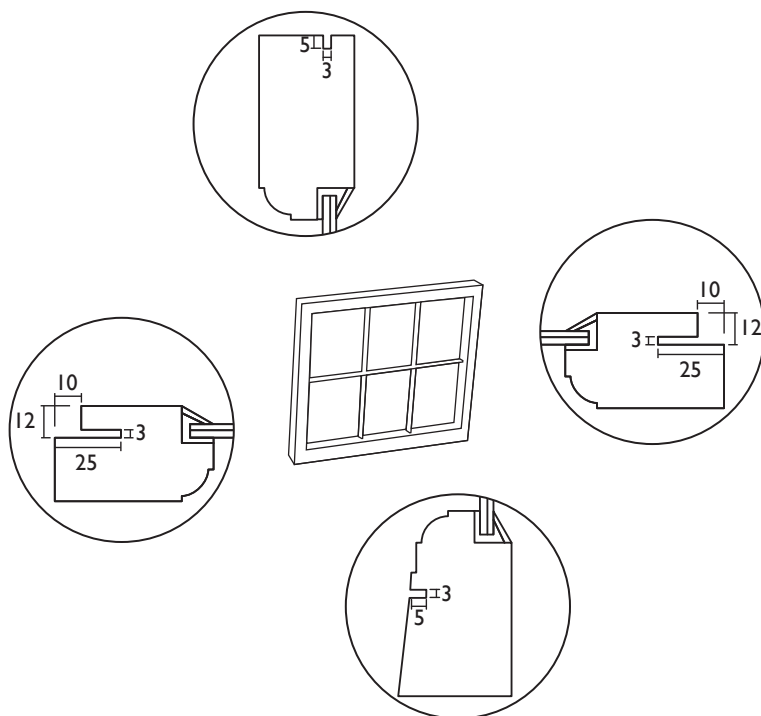

- . Rout or saw the side rebates (10x12mm with a 3mm groove) along the entire side of the sash window on both sides, using a router and/or a groove saw.
- . Follow the edge of the sash window when routing.
- . If the window is significantly warped or worn, adjust these measurements according to section D in this guide.
- . If only the top window slides, rout a 3mm wide groove, approximately 5mm deep, across the entire width at the movable sill. Do this in a suitable section where the angled or flat protruding edges of both window parts meet, leaving space for a 6mm O-rubber.
- . If necessary, adjust the movable sill with a small strip of wood to accommodate the groove in both parts. See also C-04.
- . If the bottom window also slides, it already has a groove and a seal at the movable sill.
- . Provide the upper side, the top sill, with the same groove across the entire width.

II manual for sash top window

- 3** Cut the window strips on the left and right to the correct height, trim the O-profiles at the top (small) and bottom (large) to the correct width and press them into the rebates of the sash window.

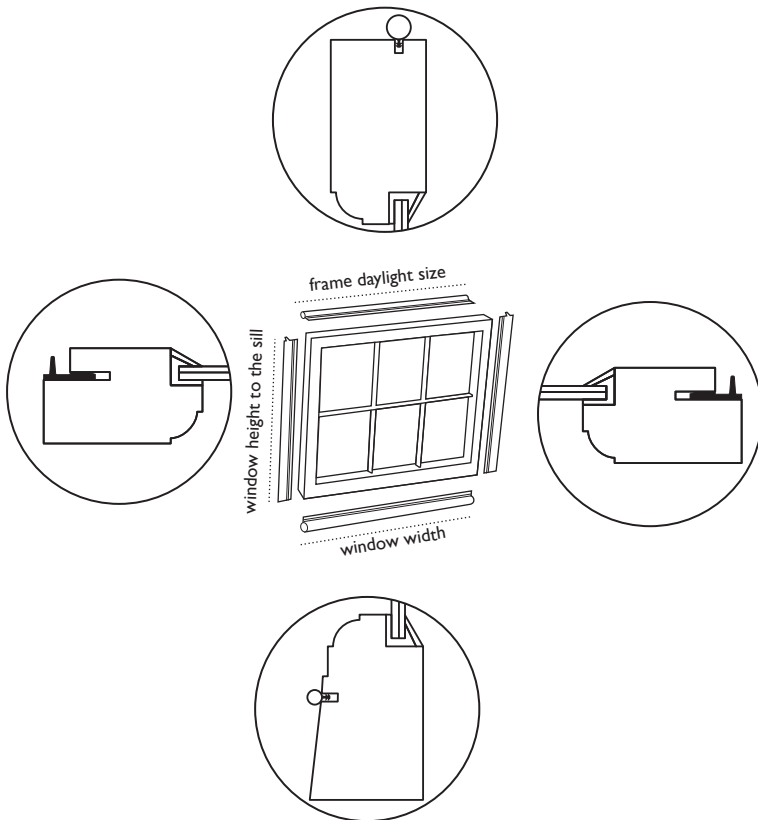

- Trim the window profiles to match the height of the sash window. Ensure that, in the closed position, the profile fits precisely between the top sill and the bottom of the top window (see drawing).
- A slight deviation in this measurement is not a problem, but a profile that is too long may be visible, while a profile that is too short could allow more air and drafts to pass through.
- Press these profiles with the sawtooth ribs on the left and right into the sash window. Tap the profile on the outside to align it with the side of the wood for proper positioning (see drawing).
- Adjust this for a severely warped or worn window according to the alternative detailing in section D.
- Ensure that, in the closed position, the profile comes exactly up to the top sill.
- If the routed groove is too large, the profile can be secured with a bit of glue or held in place with a few nails.
- Cut a small O-profile (6mm O) to size so that it fits precisely within the daylight dimensions of the frame (see drawing), and press it into the groove created at the movable sill.
- Cut a large O-profile (10mm O) to size for the top connection, ensuring it fits precisely within the left-right guide, the rebate size (see drawing), and press it into the top side.
- Do not stretch these profiles when cutting to size or during installation.

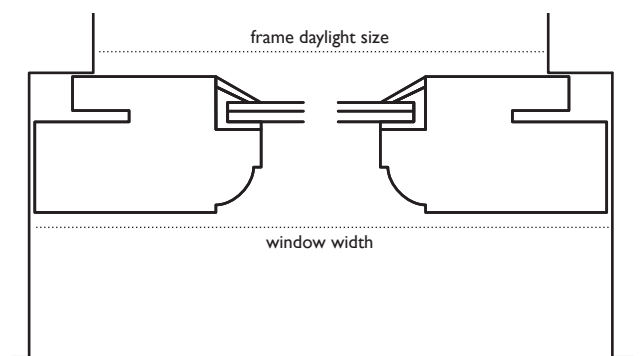

II manual for sash top window

- 4** Cut the frame strips to this height measurement and screw them into the corners of the frame on the left and right, at the bottom up to the sill, using the appropriate Torx 6 bit.

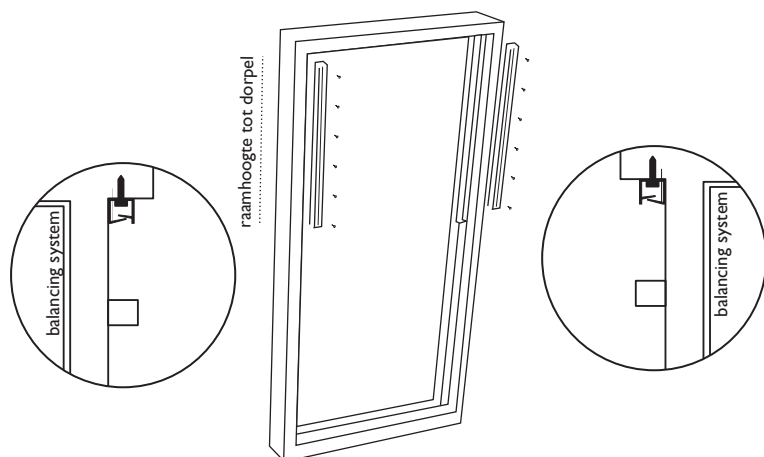

- 5** Dampen a clean cloth with VR Finish or silicone spray and wipe the frame profiles with it. Be careful not to touch the woodwork, as it may affect the adhesion of the paint.

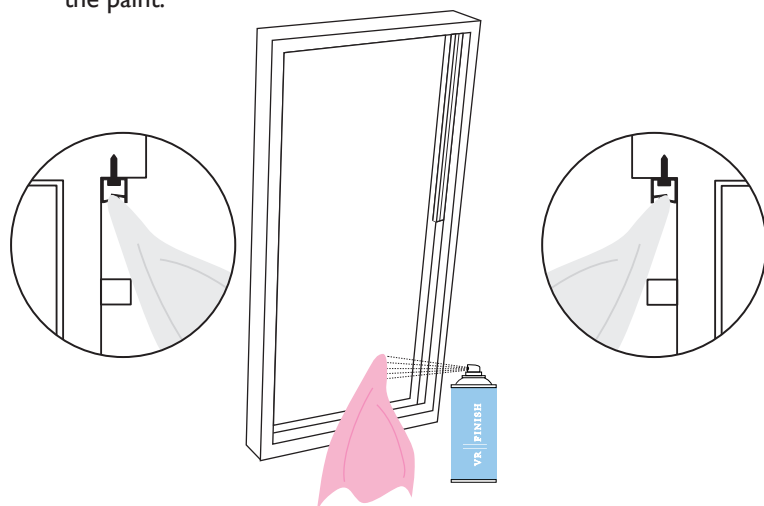

- . Cut the frame profiles (black-grey U-shape) to the same size as the window profiles (black L-shape). The profiles do not have a left or right side for use.
- . If the window has a sash height greater than the sash window height, always keep the frame profile slightly longer than the final sash height, so that the profiles remain slightly engaged with each other. This is similar to D-02.
- . Screw the profiles into the window track of the frame using the provided screws, at the top against the top sill.
- . Use all the holes in the profiles and tighten the screws only until they are snug against the profile, to avoid forcing them through the profile.
- . The easiest method is to first drive the screws into the shortened profiles by one turn on a table, so they stay in place. Then, position the profiles in the frame and tighten everything securely.
- . Check if the frame profiles are free of dust and dirt, and clean them with a cloth if necessary, using a mild cleaning agent before applying VR Finish.
- . Evenly rub both lips of the frame profiles with a thin layer of VR Finish.
- . After this step, avoid letting the frame profiles come into contact with dust and dirt to ensure optimal performance.

II manual for sash top window

- 6** Carefully place the sash window back into the frame, ensuring that the window profiles fit into the frame profiles, and reconnect the balancing system.

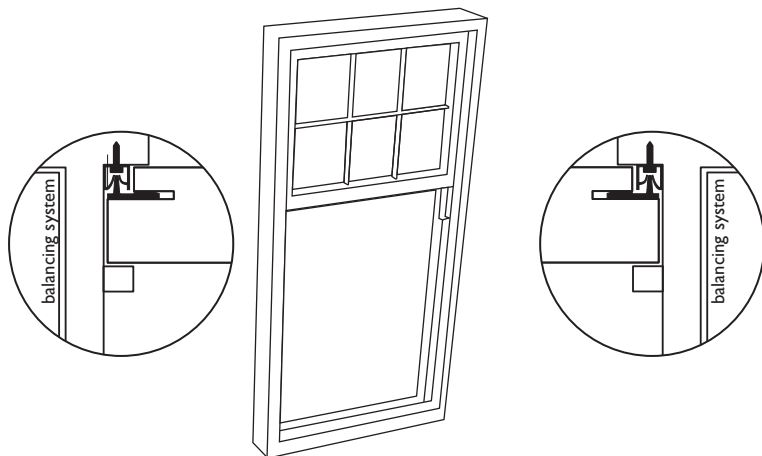

- Place the window back into the frame, ensuring that the profiles interlock with each other. See the drawing for reference.
- Approach the frame as straight as possible from the inside to ensure that the profiles are properly positioned in relation to each other.
- Ensure the window is stable and secure before releasing it.
- Reconnect the balancing system.

If the sash window has been replaced with insulated glass, don't forget that the balancing system will likely need to be adjusted to accommodate the new weight for smooth operation. To do this, replace the springs or weights, or safely add extra weight to the existing ones.

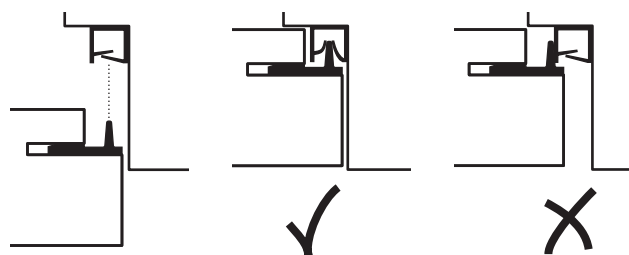

III Cross-sections & alternatives

On the following pages, cross-sections of the VR Strips application are drawn. For certain situations, alternative applications have also been drawn, which you can adapt according to your needs to customize VR Strips for your specific situation.

The cross-sections are drawn to scale 1:2, with measurements indicated in mm.

The cross-sections are drawn with a standard frame thickness of 36 mm, unless otherwise specified. Alternative frame thicknesses are outlined in section D.

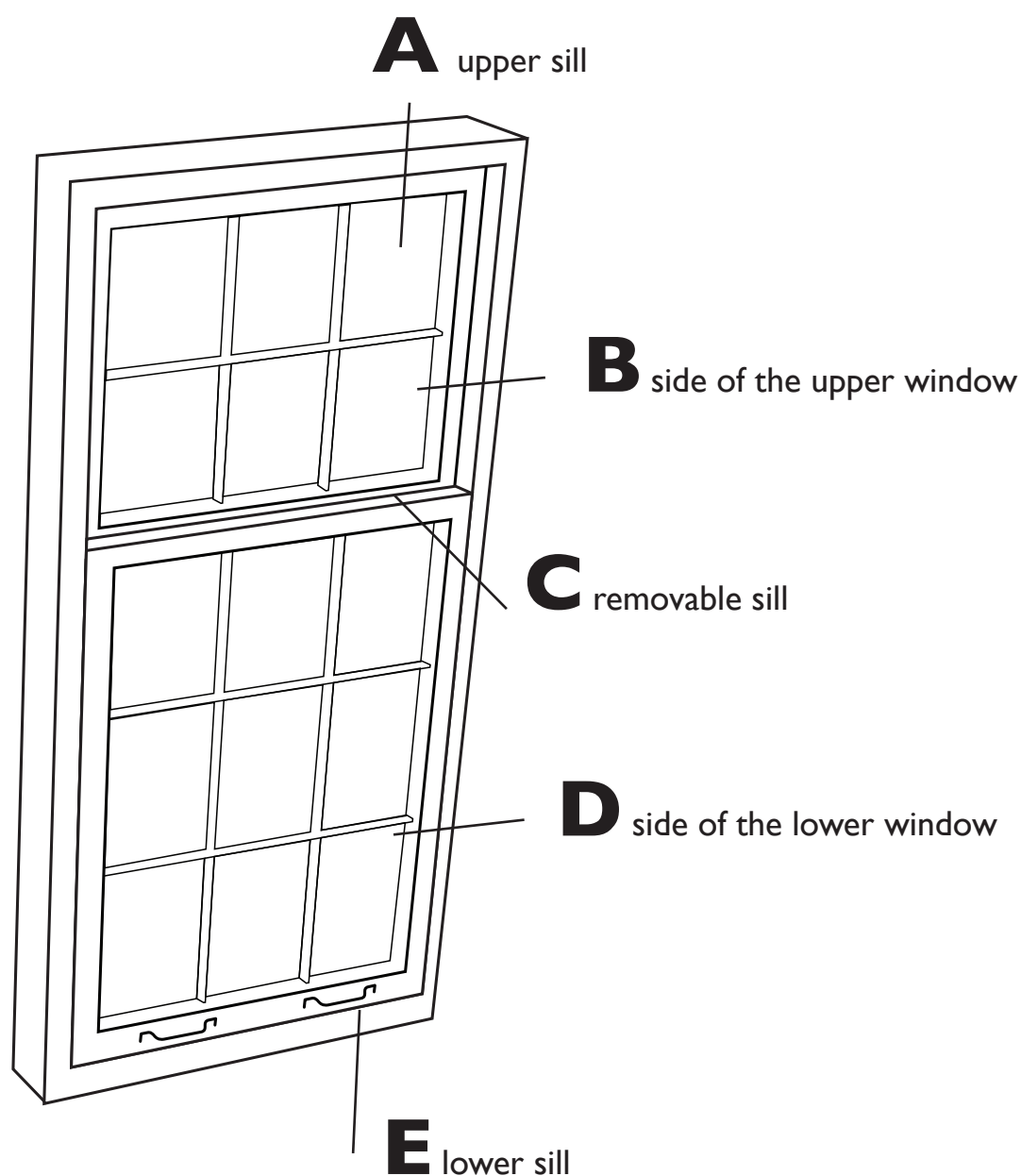

AI Upper sill

III cross-sections & alternatives

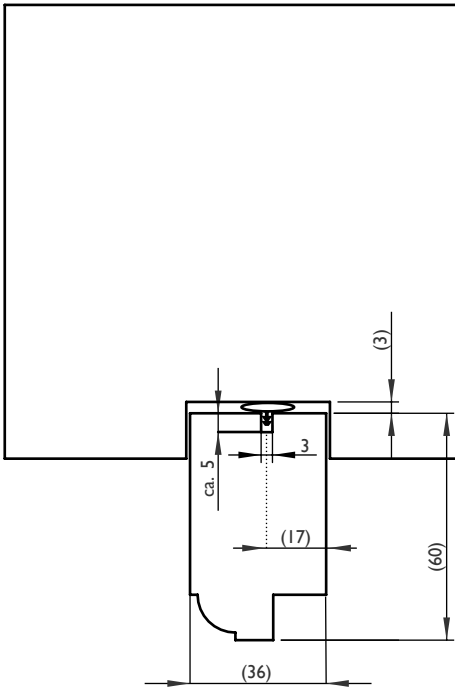

For (natural) ventilation at the top, see:V extras.

BI Side of the upper window

III cross-sections & alternatives

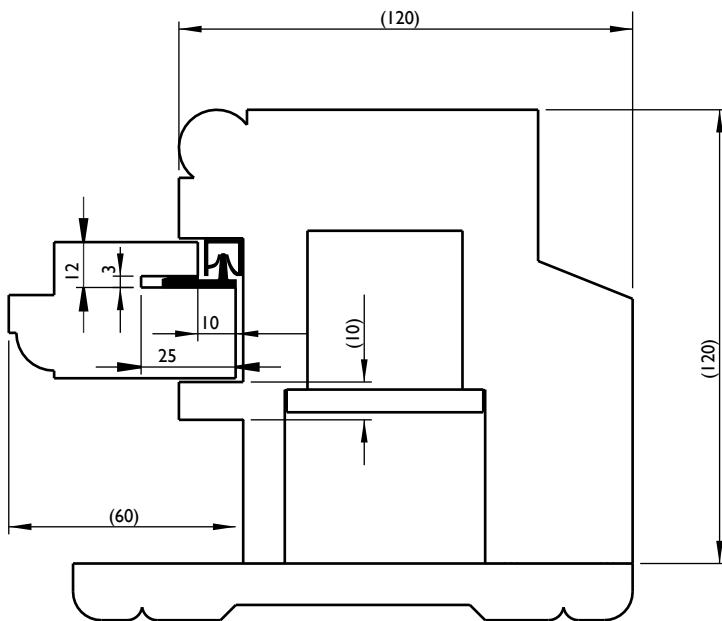

Coupled balancing systems with simultaneously or separately sash top and bottom sashes, as well as double-sash frames with shared weight in the central stile, can be easily implemented with VR Strips.

C1 Removable sill

III cross-sections & alternatives

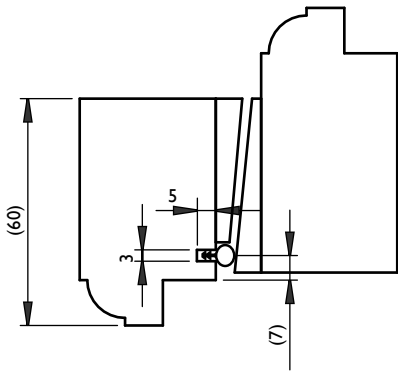

C2 Removable sill

alternative

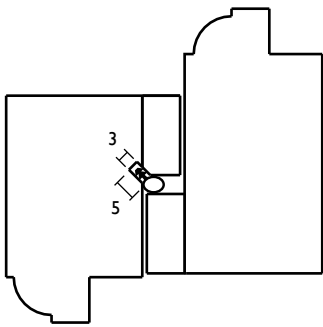

C2 Removable sill

alternative

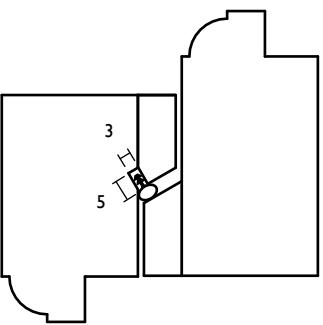

There are many more alternative changing sills possible with these profiles, application according to your own judgment.

D1 Side of the lower window

III cross-sections & alternatives

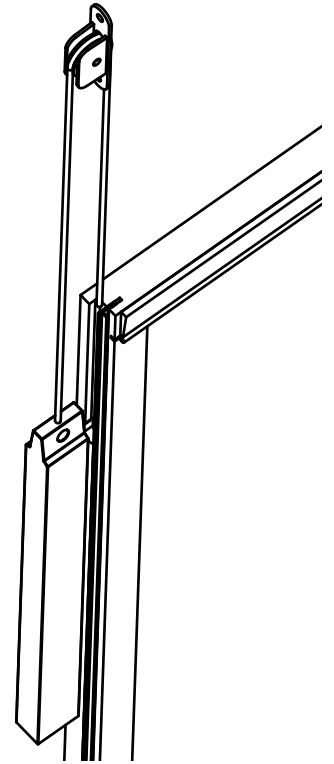
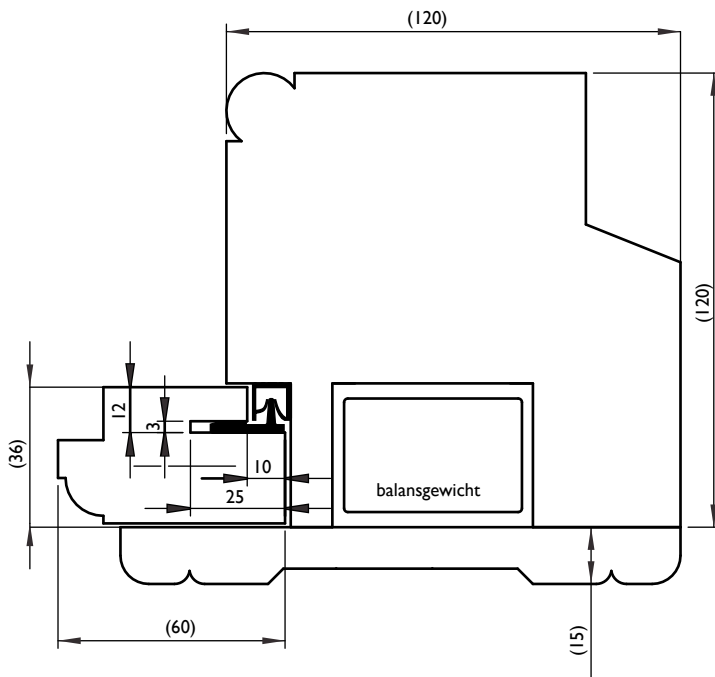

- . Bij erg kromme of versleten ramen zie:
VI bijzondere situaties
- . Uitleg over het toepassen van een pen als slot, zie:
V Extra's

D2 Side of the lower window

alternative - other wood thicknesses

Thicker versions for the window are no problem for the VR Strips and are self-explanatory. Thinner wood is also possible in many cases. A cross-section of the window-frame style for 30mm thick wood is shown here as an example, with the groove for the cord shifted.

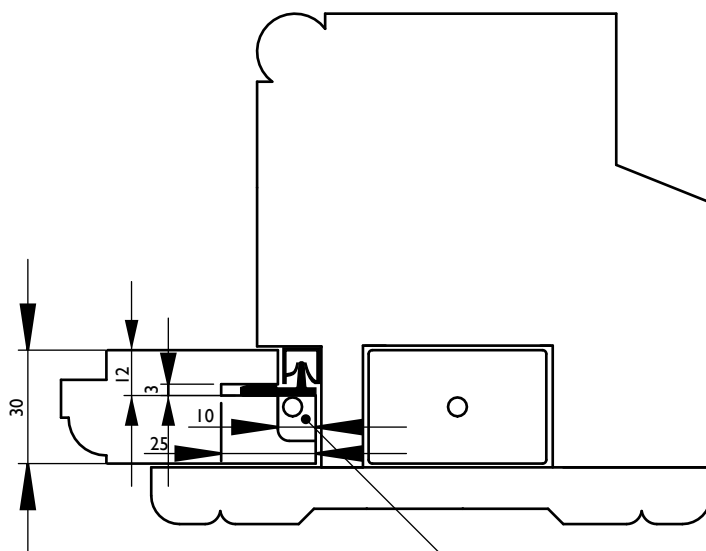

shifted groove for the cord

D3 Side of the lower window

III cross-sections & alternatives

alternative - balance springs in casing (Houtje-Touwtje system)

If the counterweight in the weight casing is replaced by a balance spring, the system still uses a rope and pulley. This allows the balance system to be significantly increased in weight — for example, after the installation of insulating glass — without the need for any visible modifications. This system utilizes a special rope and pulley with ball bearings, and can be acquired as a complete unit from HappyLift. This modification has no impact on the application of VR Strips.

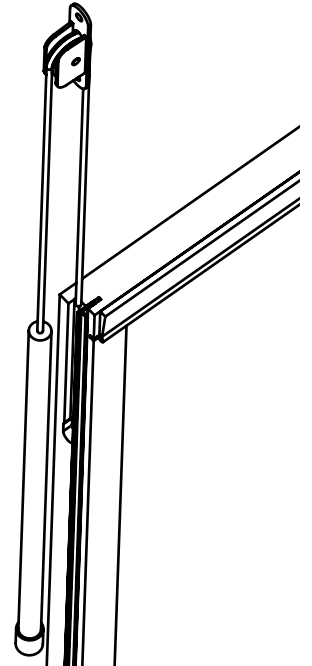
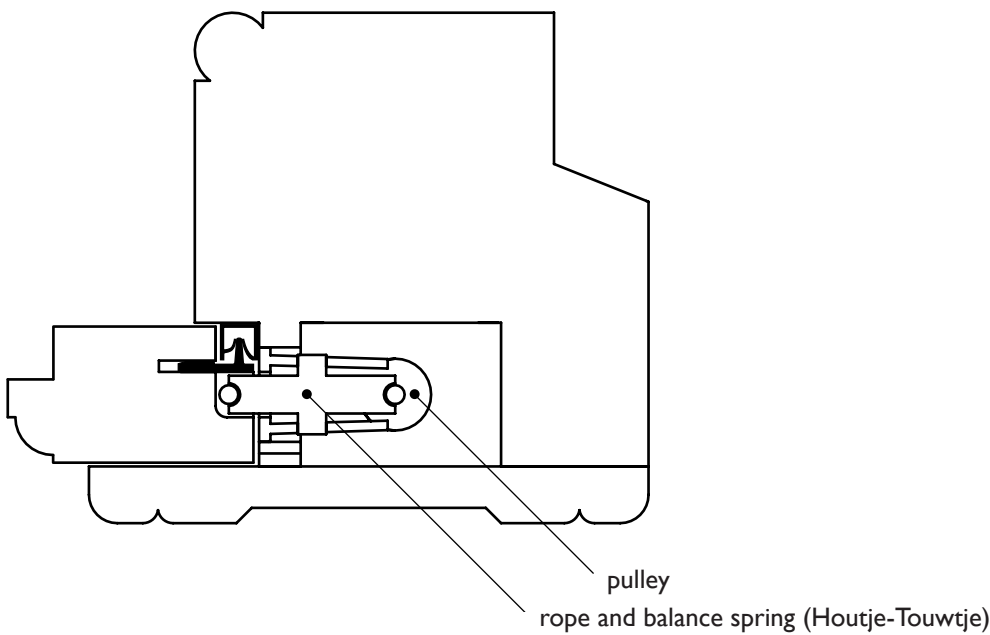

D4 Side of the lower window

alternative - balance springs in the sash window

The balance springs can also be built into the sash window itself. This way, the weight box remains unaffected. This method is slightly less aesthetically pleasing - as the springs are visible - and requires a considerable amount of space, but it can be used with thicker windows. The groove for the spring must have space next to the installation area for the VR strips. Here, it is shown with a spring in a 20mm groove. For information on the groove and installing the spring, please refer to HappyLift.

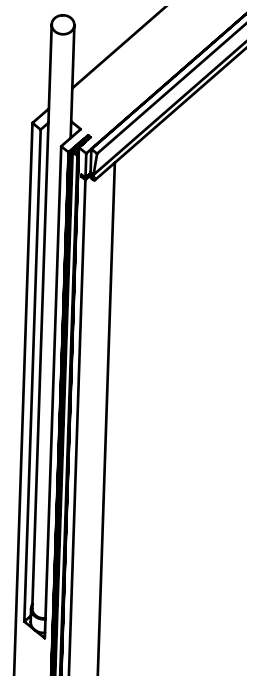
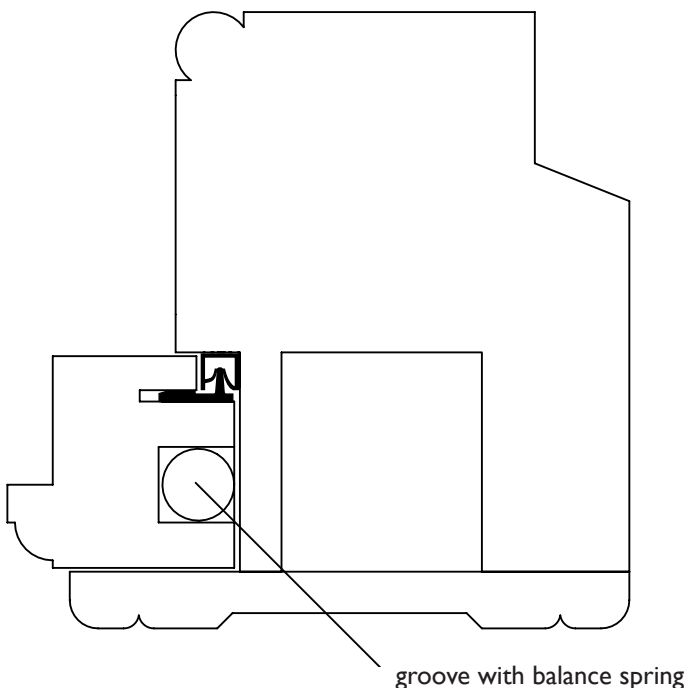

E1 Lower sill

III cross-sections & alternatives

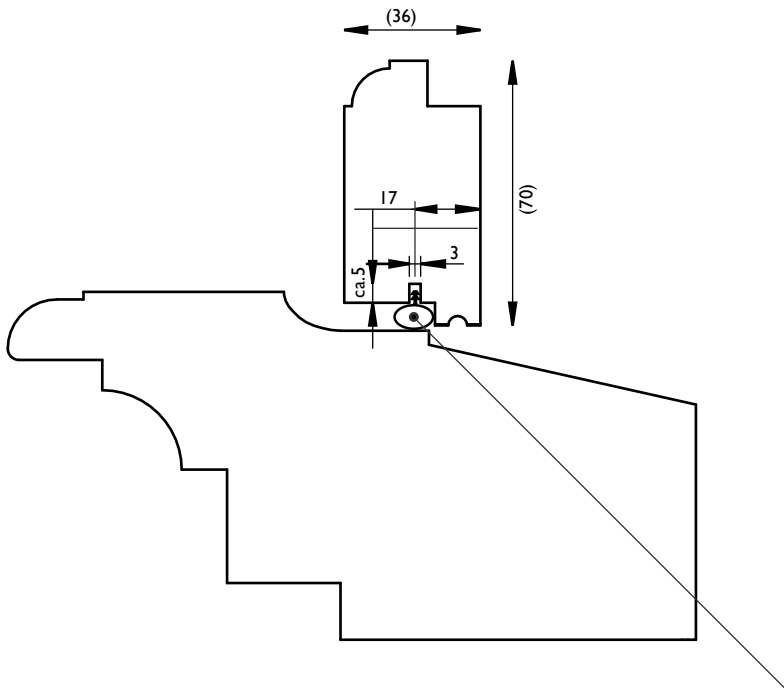

This position for the O-profile is ideal because it forms a closed frame with the strips on the sides.

E2 Lower sill

alternative

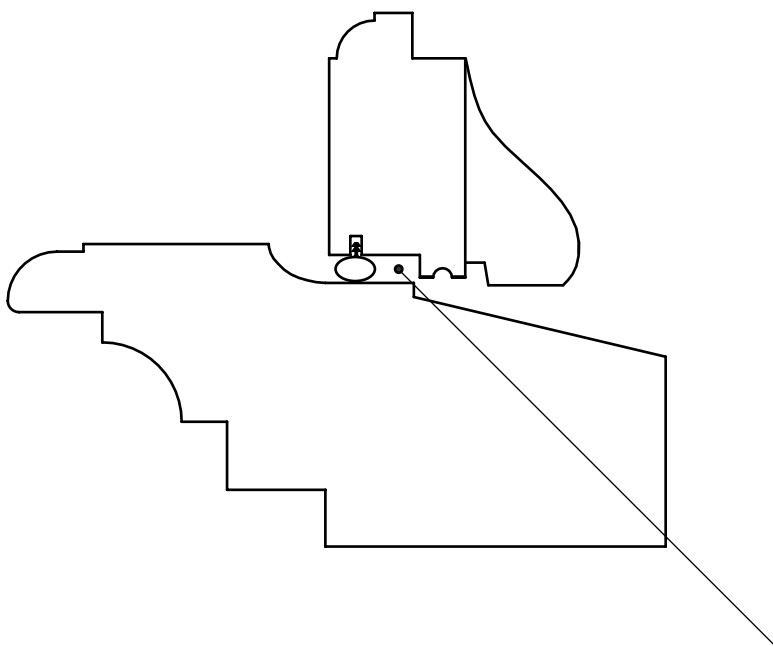

This position of the O-profile is also possible, but it creates a small gap between the O-profile and the strips on the sides.

E3 Lower sill

alternative - flat threshold

III cross-sections & alternatives

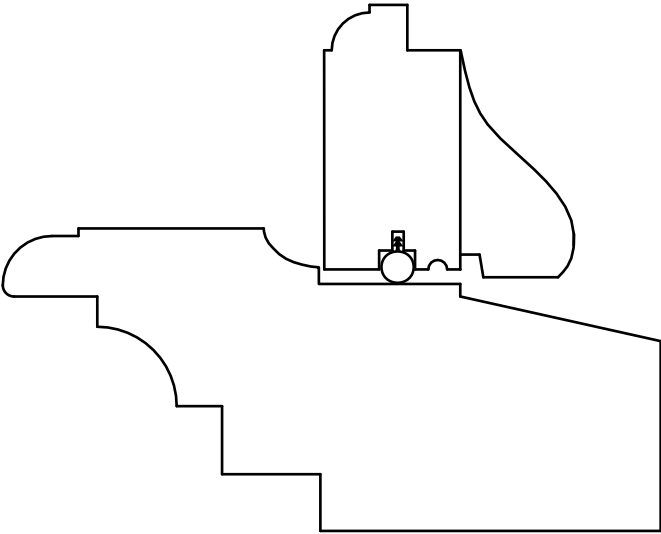

IV Special situations

In this chapter, some special situations are addressed where the application of VR Strips requires extra attention. In general, VR Strips can be applied without any issues, but to achieve an optimal result, it is sometimes necessary to perform additional work.

severely worn windows

- . For old windows that are severely warped or where significant wood has worn away, the VR Strips can be installed while maintaining the original dimensions.
- . Ensure that when milling the required rebates (10x12mm), the window does not fall through the frame or that the milled-out area becomes visible from the outside. This can be resolved by marking the milling dimensions from the center and relating the measurement to the frame. Avoid following the curvature of the wood; instead, mill straight, effectively maintaining the original dimensions.
- . For guiding the window, an additional strip can be inserted (see drawing) to restore the window to its original width.
- . Consider whether it might be better to restore the sides (the outer edges) by gluing a new piece of wood onto them to make the whole structure straight.
- . During installation, do not push the window profiles completely against the worn-down side, but position them from the center of the window up to the frame dimensions. See drawing. Nail or glue them in place if necessary.

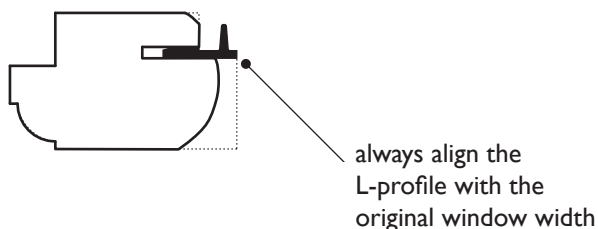
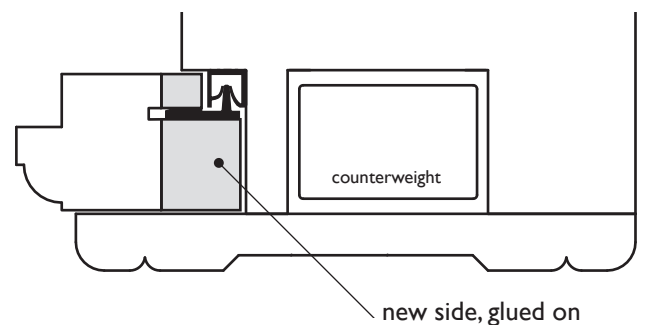
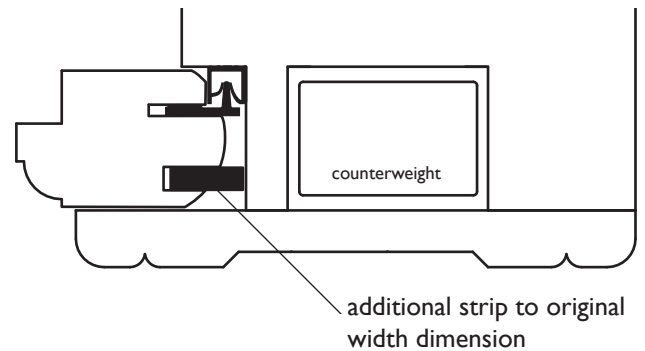
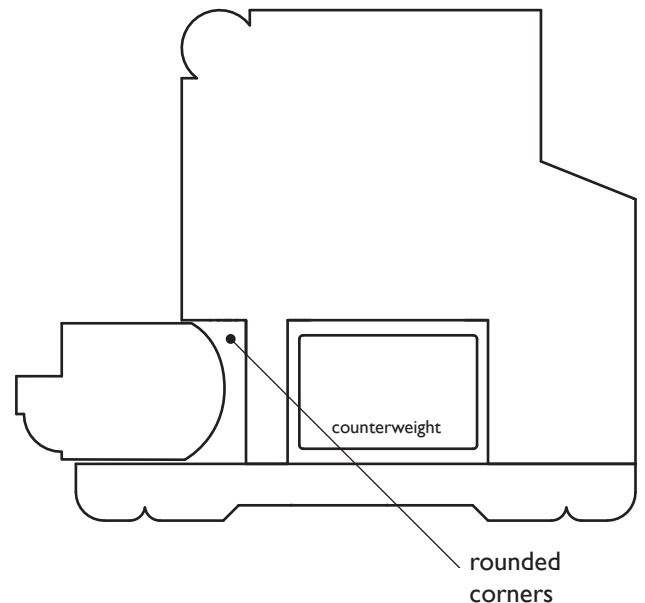

IV special situations

A lot of play between the window and the trim strip

Due to wear on the window, it may have too much space relative to the frame because of the trim strip. In that case, the sealing of the VR Strips will also be less effective. Therefore, push the window slightly outward using felt pads or a strip on the trim.

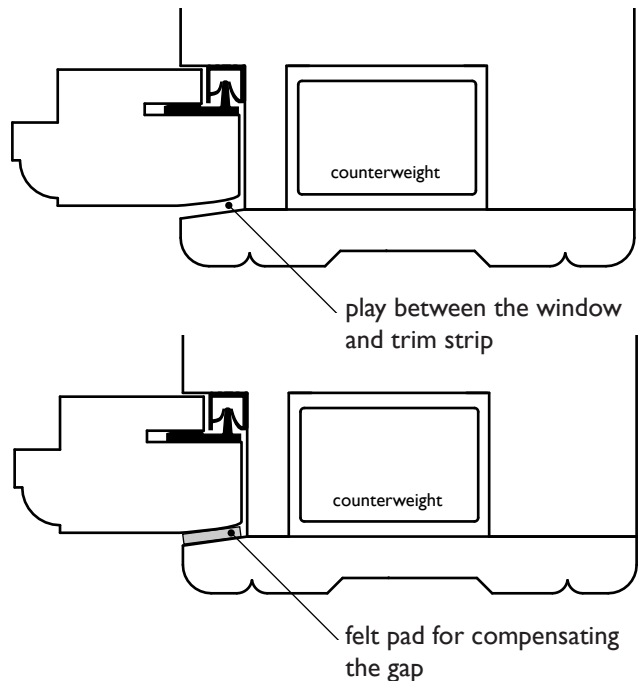

Large sash height relative to the sash window height

If the sash height is equal to the height of the sash window, it must be ensured that the profiles always remain slightly interlocked. To achieve this, the frame profile can be extended by a few centimeters. The window profile (L) does not need to be adjusted.

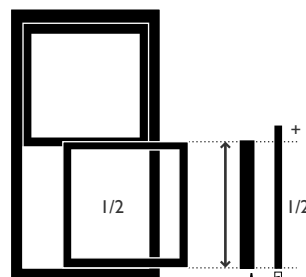

For a window where the sash height is greater than the sash window height (a small sash section with a large height), the frame profile must be as long as the sash height. The window profile (L) does not need to be adjusted. As a result, the frame profile will protrude slightly above the edge of the sash window when closed, but this will be behind the trim, so it will not be visible.

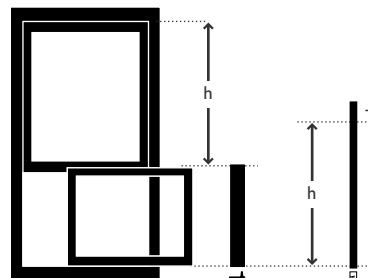

very large windows

The profiles are available in different lengths upon request. However, keep in mind that with very large windows, there will also be more friction. A larger window is already difficult to move due to its mass, but there is also more friction in the profiles.

V Extras & extensions

VR Strips, thanks to its minimal installation space, generally does not affect additional functionalities of the sash window, such as ventilation or a lock. Below are some cross-sections to illustrate how these products can be applied together.

Ventilation

A good way to achieve natural insulation in the home is by omitting the O-profile at the upper threshold or changeable threshold, depending on the window. The supply of fresh air at that height is not disruptive and ensures healthy air circulation in the house.

A closable vent, as drawn below, combined with the O-profile, allows the ventilation to be opened or closed.

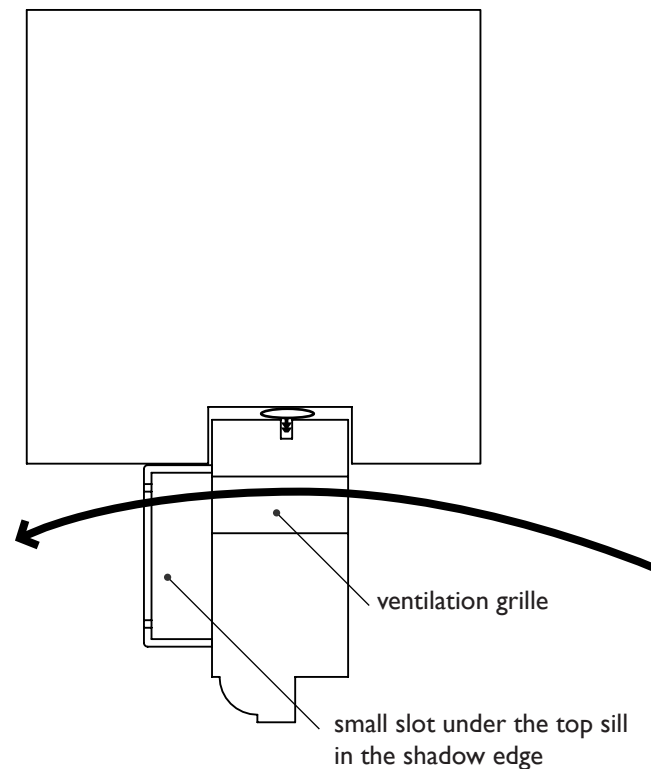

Conclusion

A pin that secures the sash window to the trim is the traditional and durable way to lock the window. The closure with a classic pin can be made more robust by reinforcing the wood-to-wood connection with a metal plate.

Additionally, locks with a security certificate can be applied to the sash window. This can be done on the bottom sill or at the top of the sash lower window. It can be applied according to your preference, ensuring that it is accessible and does not become an unsightly addition. More information about this can be obtained from a hardware supplier.

The solutions described here are just two of many possibilities, all of which can generally be excellently applied in combination with VR Strips.

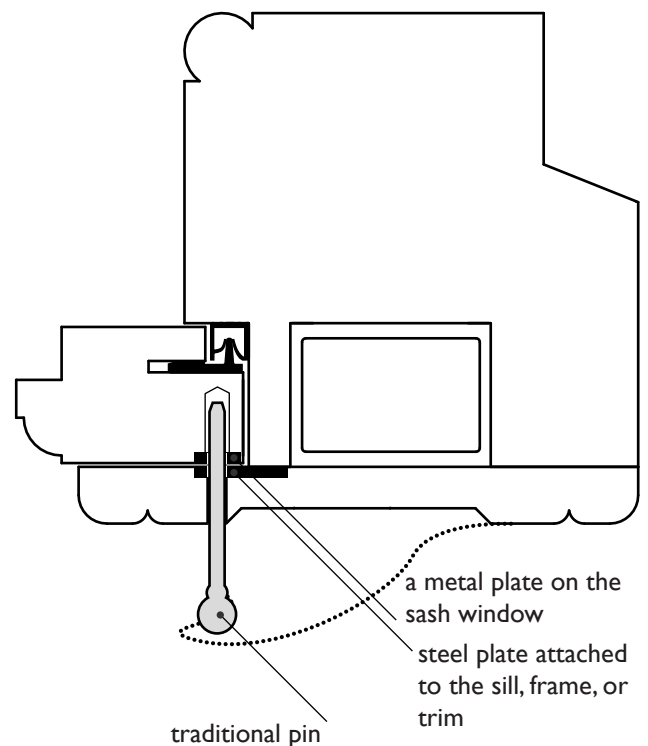

VI Usage & maintenance

VR Strips require minimal attention in terms of use and maintenance. However, here are a few key points to ensure optimal convenience.

Use

- . VR Strips have no impact on removing the window, for example, during a move. However, when reinstalling, make sure that the profiles interlock properly.

Maintenance

- . Remove any debris, dust, etc., from the frame profiles once a year.
- . Treat the VR Strips with VR Finish once a year, depending on the frequency of use. To do this, slide the window open as far as possible and treat the visible parts of the frame strips.

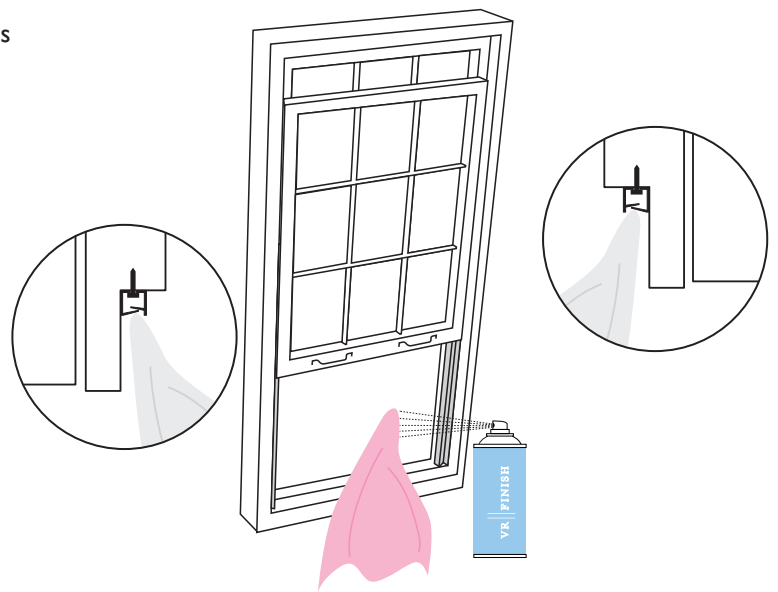

VII Possible issues with VR Strips

In case any issues arise during or after installation, please check below for a suitable solution. If your issue is not listed or cannot be resolved, visit www.vanruydael.com for more information and contact details.

The window cannot be properly installed

- Make sure that the window profiles are pressed flush with the side of the sash window. For worn windows, these profiles should align with the flat or original side of the sash window.
- When placing the window, make sure that the window profile is positioned as centrally as possible between the lips of the frame profile on both sides. If necessary, adjust the position of the window profile relative to the side of the sash window.
- Check if both the window profile and the frame profile are made from a single piece on each side.

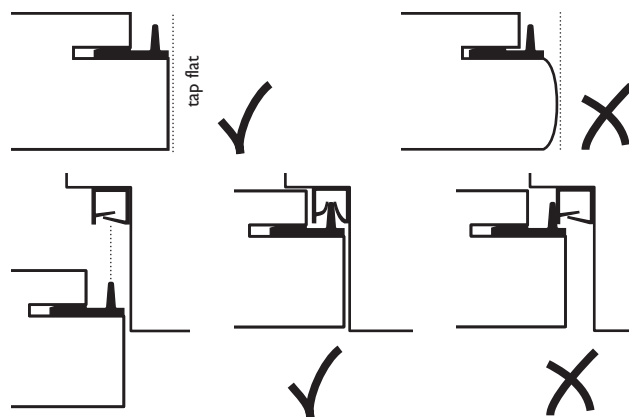

Draft under or through the side

- If the O-profile is not mounted in the prescribed position (see III E1) at the bottom, a small gap may form through the side-bottom. If necessary, adjust the detailing of the sill to allow the O-profile to be applied in the prescribed position.
- If the sill has sagged significantly, it may be that the 10mm O-profile cannot compensate for the difference. Make the connection more precise by adding a flat piece to the sill or by adjusting the sash window to accommodate the sagging sill.
- Draft through the sides can occur if extra play develops due to wear of the window or the trim, allowing the window to sit too far inward. In this case, the profiles may not latch together properly. Use felt pads (see section IV special situations) to improve the position or restore the window to its original, non-worn state.

Draft at the exchange sill

- Check if the O-profile is positioned so that when the window is closed, this profile is pressed along its entire length. Adjust the groove position if necessary.
- If the gap at the sash sill is too large, a larger O-profile can be used.

Window profile is loose

- If the groove in the sash window is slightly too large, it may cause the window profile to shift relative to the window when opening and closing.
- The profile can easily be glued into the groove or secured with a nail through the outer side (out of sight) of the sash window.

Difficult to open/close

- . Check if the weight of the window corresponds to the weight of the balance system. If new glass has been installed, the additional weight may need to be adjusted in the system. This can be done by adding mass to the counterweights or replacing the old weight with a customized one. In the case of balance springs, it may be necessary to order and install new springs.
- . Check if the play (gap) of the window in the frame does not exceed a few millimeters. If necessary, correct it using a guide block, see: IV special situations.
- . Check whether the positioning of the window profiles in relation to the frame profiles is correct. Do they fit together neatly? If necessary, correct by moving the window profile in the groove, aligning it with the measurements of the frame, see: IV special situations.
- . Feel along the fastening screws in the frame profile to check if they are tightened enough. Tighten them as much as possible against the profile, without forcing them.
- . Is there any debris/splinters/trash in the frame profiles? Remove the window and vacuum between the profiles.
- . Optionally, run a bit of talcum powder along the window profile to reduce friction. Do not use oil or lubricants that can attract dust.
- . Over time, the profiles may become less smooth to slide. In that case, treat the smooth inner sides of the frame profiles with silicone spray or liquid, and allow it to dry thoroughly.